



Weigh Pack Electrical

MODULAR SINGLE IDLER BELT WEIGHER MODEL MBS

Features

- Highly accurate, proven and rugged design
- Fully floating weigh carriage for simple calibration
- Cost effective modular design
- Dual load cell configuration for belts >1600mm
- Integrated test weight receptors or optional lever arm operated stored in place test weights

Application

Belt Weighers are used for the continuous acquisition of flow rates and totalised amounts. They are especially designed for integration into belt conveyors and enable accuracies of up to $\pm 1\%$. They can be employed for a variety of tasks:

- Throughput and consumption measurement of production rates in plants
- Accountability of received and shipped amounts
- Maximum or minimum load limit alarms
- Batching, in loading stations
- Pre-feeder control

The sturdy design ensures a high degree of reliability and availability.

Construction

The standard belt weigher comprises:

- Fully floating weighing platforms
- Overload-protected stainless steel load cell(s) of IP65 construction
- IP65 cable junction box in painted mild steel
- IP65 Tail drum speed sensor
- Mounting and adjusting bolts

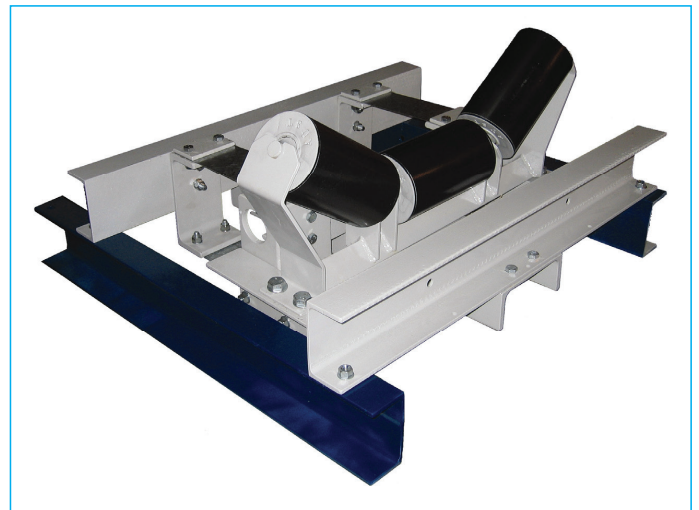

Options include:

- Weigh quality idler sets with screw adjustment (for precise idler alignment, $\pm 0.2\text{mm}$)
- IP65 cable junction box in 316 stainless steel
- Friction jockey wheel running on return belt

Operating Principle

The belt weigher comprises load cells that measure the load on the weigh length while a speed transducer acquires the belt speed. The controller calculates both the instantaneous load and the totalised amount. The MBS features a single centrally mounted load cell with maintenance free spring flexure arrangement for belt widths under 1500mm and two flexure assemblies with load cells for the wide belts to account for the large side forces. The modular design also results in a lighter construction better suited to the working range of the load cells.

Specifications

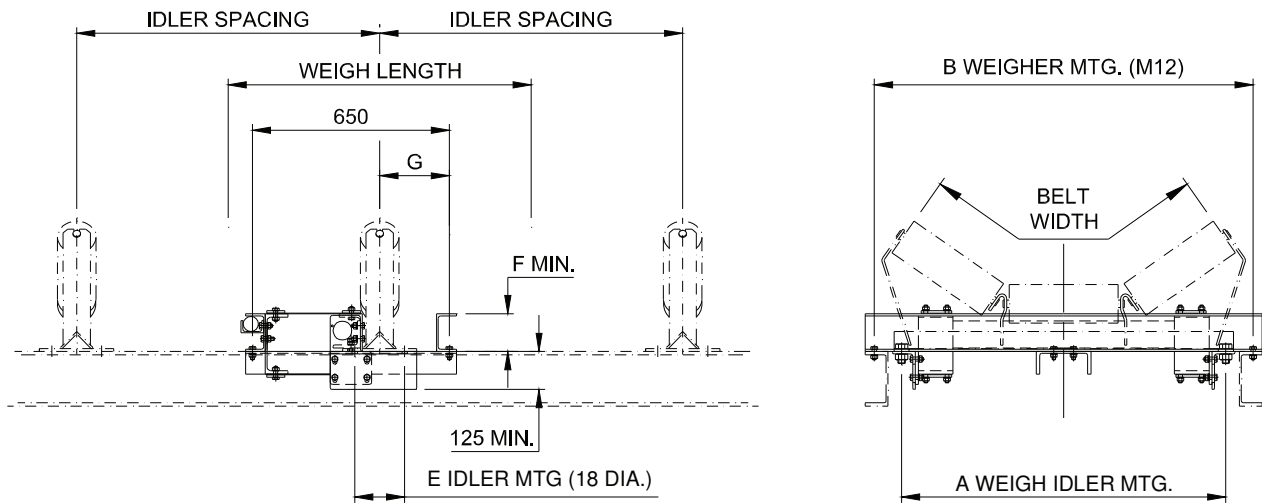

Standard Models

MBS.1 single load cell with dual flexure design for belt widths 500mm to 1500mm. MBS.2 dual load cell four flexure design suitable for belt widths 1600mm to 2500mm.

Model	Accuracy	No. L/C & Modules	Weight (kg)	A	B	E	F	G
MBS.1.500	±1%	1	75kg	570	750	60	750	215
MBS.1.600	±1%	1	80kg	670	850	60	850	215
MBS.1.650	±1%	1	83kg	720	900	60	900	215
MBS.1.750	±1%	1	88kg	820	1000	60 140	1000	215 245
MBS.1.800	±1%	1	90kg	870	1050	60 150	1050	215 235
MBS.1.900	±1%	1	96kg	970	1150	60 150	1150	215 235
MBS.1.1000	±1%	1	101kg	1070	1250	60 150	1250	215 230
MBS.1.1050	±1%	1	118kg	1120	1300	60 150	1300	215 230
MBS.1.1200	±1%	1	128kg	1270	1450	60 165	1450	215 230
MBS.1.1350	±1%	1	141kg	1470	1650	180	1650	220
MBS.1.1400	±1%	1	155kg	1520	1700	200	1700	210
MBS.1.1500	±1%	1	162kg	1620	1800	200	1800	210
MBS.2.1600	±1%	2	189kg	1820	2000	240	2000	250
MBS.2.1800	±1%	2	198kg	2020	2200	240	2200	250
MBS.2.2000	±1%	2	221kg	2220	2400	280	2400	230
MBS.2.2200	±1%	2	233kg	2320	2600	280	2600	230
MBS.2.2400	±1%	2	246kg	2520	2800	350	2800	200
MBS.2.2500	±1%	2	252kg	2720	2900	350	2900	200

Custom designs to suit non standard conveyor stringers, idler spacing and idler dimensions are also available on request. Accuracy quoted is based on maximum belt speed of 5m/s and is subject to confirmation by formal quotation. Belt weighers should be installed in accordance with the operating and installation manuals. Dimensions and specifications are subject to change without notice.

Email: Sales@weighpackelectrical.com.au
Service@weighpackelectrical.com.au

Phone: 0488 199 318